



THE TRAVELLER STOVE



ANEVAY

Contents

Congratulations

A Note on the Clean Air Act

For Your Safety

Getting to Know Your Traveller Stove

Unpacking Your Traveller Stove

Traveller Stove Dimensions

Installation and Use of the Traveller Stove



Congratulations on your purchase of the ANEVAY TRAVELLER™ stove.

The Traveller™ Stove is part of a family of unique and lovingly crafted stoves that are built to last. When properly installed and maintained it will give you many years of service, warmth and lots of happy memories.

With years of experience designing and manufacturing stoves, ANEVAY have designed this stove to be incredibly efficient and cleanburning. This means a highly effective air wash system, keeping maintenance to a minimum.

It also means you use less fuel, saving you money and limiting environmental impact. All stoves are finished to the highest standard and meet UK and EU safety and environmental requirements.

We always recommend having your stove installed correctly by a professional, HETAS approved engineer. Your stove retailer can help find the right person for you or you can find one online at www.hetas.co.uk/find-installer. Please read through this manual carefully before your stove is installed, and keep it somewhere safe for future reference. If you have any questions regarding the information given here please contact: info@anevay.co.uk.



A Note on The Clean Air Act and Smoke Control Areas

Under the Clean Air Act 1993 local authorities may declare the whole or part of the district to be a smoke control area. It is an offence to emit smoke from a chimney of a building, from a furnace or from any fixed boiler if located in a designated smoke control area.

It is also an offence to acquire an "unauthorised fuel" for use within a smoke control area unless it is used in an "exempt" appliance ("exempted" from the controls which generally apply in the smoke control area). The Secretary of State for Environment, Food and Rural Affairs has powers under the Act to authorise smokeless fuels or exempt appliances for use in smoke control areas in England. In Scotland and Wales this power rests with Ministers in the devolved administrations for those countries. Separate legislation, the Clean Air (Northern Ireland) Order 1981, applies in Northern Ireland. Therefore it is a requirement that fuels burnt or obtained for use in smoke control areas have been "authorised" in Regulations and that appliances used to burn solid fuel in those areas (other than "authorised" fuels) have been exempted by an Order made and signed by the Secretary of State or Minister in the devolved administrations.

Further information on the requirements of the Clean Air Act can be found here: www.smokecontrol.defra.gov.uk. Your local authority is responsible for implementing the Clean Air Act 1993 including designation and supervision of smoke control areas and you can contact them for details of Clean Air Act requirements.

For your safety

Always keep a fire extinguisher on hand when operating your stove. A carbon monoxide alarm and smoke detector should be fitted at all times to ensure early detection of any harmful emissions.

If you are experiencing any problems with your stove, such as excessive smoke or a poor draw, close down all vents, open any doors and windows to ventilate the room and contact a HETAS-approved engineer before relighting.

In the event of a chimney fire, close down all air vents and call the fire brigade (999). Move all combustibles away from the area surrounding your stove. Do NOT pour water on the fire.

The ANEVAY Traveller™ Stove is designed as a wood-burning stove. It should not be used as an incinerator or to burn general waste. ANEVAY do not recommend the use of liquid fuels in lighting your stove. No part of the Anevay Traveller™ Stove shall comprise any material known to be harmful. The appliance is not suitable for use with shared flues.

Technical Specifications of the Anevay Traveller Wood Stove:

Height	52 cm
Width of stove body	28 cm
Depth	40.5 cm
Flue diameter req.	4"
Net weight.	24 kg
Nominal heat output	3.9 kW
Heat output range	3.5 - 3.93 kW
Flue temperature	151.3°C
Minimum flue draught	11.13 Pa
Flue gas mass flow	3.84 g/s
Net Efficiency	87.4 %

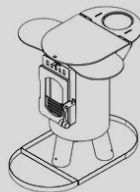

Getting to Know your Traveller Stove

The Traveller Stove is a front- and top-loading wood burner, designed specifically with semi-permanent glamping setups and small spaces in mind. It has primary and secondary air controls. The top surface can be used to boil a kettle on and the 'wings' on the winged model can be used as hot plates. It produces 3.8 kW of heat.

Stove lid: lift this upwards to load wood into the fire box once the fire is established. Stove lid must remain closed at all times when operating in a permanent dwelling.

Primary air control: allows air in through the first catch on the door. This is used initially to establish the fire. After 10 - 15 minutes, the door should be shut completely.

Front loading door: Unhook the door latch and open the stove door to load appropriately-sized wood pieces into the stove



Single Skin Flue Section: 500mm single skin flue section exiting from rear of stove.

Secondary air control: Slider vent above the stove door. This is used to regulate airflow once the fire is established.

Rope Seal: This is a special, fireproof rope seal to ensure your stove system is tight when the door is shut. The rope should always be intact and in the slot for the door.

Grate: prevents embers from falling out of the stove during refuelling through the front door and prevents contact with the stove glass door.

Base Plate: base plate is integrated with the stove. Due to the way it has been designed, there is little heat transfer to the base plate. Newer models of the stove have the base plate in the reverse position to allow for air flow underneath the plate

Unpacking your Traveller Stove

We take great care in preparing and packing your stove. The Traveller Stove comes attached to its base plate, with the following items packed separately:

- Stove door (including glass)
- Traveller stove D-plate (slots in to the base plate)
- 500mm 4" single skin flue, which must be the section that first exits the stove (sold separately)
- Traveller Stove Flue Kit (sold separately)

When unboxing your stove, take care in removing all the packaging and place on a level surface. Unwrap the stove door, being careful of the glass pane, and slot the door onto the hinges.

Next, remove the following items from the flue kit (sold separately):

Insulated Flue Kit:

- Adaptor piece which connects single skin flue section to insulated flue section
- 500mm insulated flue section
- 1000mm insulated flue section
- Flashing kit with silicone sealant and screws
- Storm collar
- Insulated anti-downdraft cowl

The Traveller stove has been tested to be used with an initial section of 500mm single skin flue exiting the appliance. Slide the 500mm single skin flue into the stove and ensure a gas-tight fit, using fire cement to seal. Slot the adaptor piece into the flue pipe on the stove. Next, connect the 500mm insulated flue section, securing with the locking band. The 1000mm section and termination can follow. See Appendix A for further fitting instructions.

The Anevay Traveller Stove is not suitable for use with shared flues.



Traveller Stove Dimensions

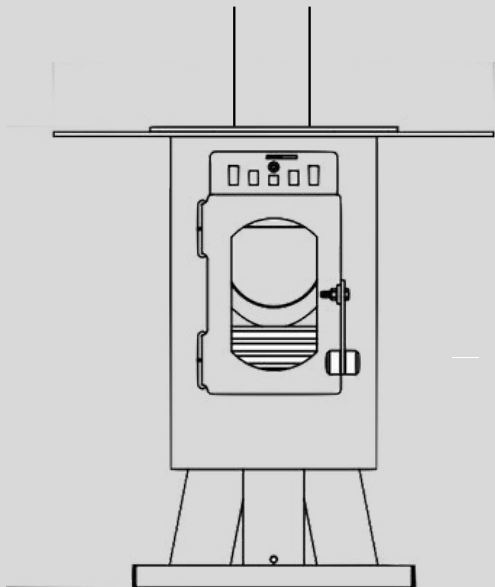

<i>Fuel Type</i>	Wood only
<i>Nominal Output</i>	3.9 kW
<i>Dimensions</i>	Height: 520mm Width: 220mm Depth: 320mm
<i>Distance to Combustibles</i>	Front: 1000mm Sides: 450mm Rear: 300mm
<i>Distance to Non-Combustibles</i>	Front: 100mm Sides: 100mm Rear: 100mm
<i>Max log length x diameter</i>	210mm x 60mm
<i>Flue exit</i>	Top only - not suitable for use with shared flues
<i>Construction</i>	Welded steel, finished with high-temperature paint
<i>Flue aperture diameter</i>	4" / 101.6mm* <small>*MUST be used with initial section of 4" 500mm single skin flue</small>
<i>Hearth Type</i>	Integrated
<i>Ventilation (if required)</i>	30mm x 40mm

Installation and Use of the Traveller Stove

Regulations

All national and local regulations, including those referring to national and European standards need to be complied with when installing the stove.

Installation

The stove must be installed by a competent person or approved by your local building control officer when subject to Document J Regulations. If installed incorrectly, serious accidents can be caused. Building Regulation Document J must be referred to when installing this appliance. It is the installer's responsibility to ensure the manufacturer's instructions are complied with.

As our stoves are designed for small spaces and quirky corners, the regulations make provision for certain situations where Document J would not necessarily apply. In these situations, we still recommend applying good practice and installing to standards.

Small detached buildings are exempt from building regulations. Outbuildings are referred to as "small detached buildings" in the Building Regulations (Schedule 2, Class 6) and are classified as "Exempt Buildings and Work", meaning you won't normally need building regulations approval, as long as the building belongs to 1 of the following classes:

- 1. The floor area is less than 15 square meters and there is no sleeping accommodation.
 2. The floor area doesn't exceed 30 square meters, the building is at least 1m from any boundary, or is made substantially of non-combustible materials.

We highly recommend consulting British Standard **BS 6762-2: 1991** when installing the stove in 'Leisure Accommodation Vehicles and Transportable Accommodation Units'.

WARNING

We recommend that you fit the Traveller Stove in any structure to the same standards that you would in a house. Some structures may not currently be certifiable by HETAS or building regulations but the risks are the same, if not greater in a small space. Combustible surfaces are likely to be closer, so it needs careful design consideration in the planning stage.

We believe that there are additional risks in canvas structures eg yurts, tipis and safari tents. Adverse weather can cause movement of the surface the flue is exiting through. The flashing must allow for some movement, and the stove and each flue section should be mechanically fixed to each other and the hearth to prevent smoke spillage under these circumstances.

We recommend that you be guided by the principle of taking all and every reasonable precaution to protect and preserve safety. This is of particular importance if users are unfamiliar with wood burning stoves and any risk factors that a single, regular user might be sensitive to.

Floor

National and local building regulations must be complied with when considering the floor or hearth where the stove is to be installed. The hearth temperature of the Traveller stove does not exceed 100 degrees celsius. The stove must be fitted on a stable, level floor with a load-bearing capacity that exceeds the weight of the stove. The stove should not be able to be moved or disturbed by foot traffic eg in a non-fixed floor in a yurt. The base of the Traveller Stove has been designed to act as a heat shield and to easily achieve stability.

Access for cleaning

Although access to the flue can be gained by removing the stove body components, consideration must be given to installing extra access in the flue system to ensure all sections can be cleaned and maintained.

Fuel

Use only kiln-dried timber with a moisture content of less than 20%. Our **eco fuel** logs made of compressed sawdust are the fuel of choice for this stove.

DO NOT BURN wet or unseasoned wood, construction timber, painted or treated wood, driftwood or manufactured board products. Doing so will result in the wood burning inefficiently and excess smoke, soot and tar will be produced. This will coat and damage the internal components of the stove and flue and could result in a chimney fire.

Do not burn bituminous coal, any petroleum based products or any liquid fuels.

Safety Clearances

When installed, the stove must comply with the following minimum safety clearances from combustible materials:

To both sides: 450mm

To the rear: 300mm

If the stove is to be installed in a non-combustible recess, it is recommended that 100mm clearance is left at the back and sides for maintenance and to allow air to circulate around the stove. Single skin flue should be **3 x the flue diameter** away from combustibles, and for twin-walled flue, manufacturer's instructions should be followed. If the Anevay flue kit is installed, the distance to combustibles should be a minimum of 50mm, including where the flue exits the ceiling / roof. The flue **must** be twin-walled as it exits the ceiling / roof / wall.

Heat Shielding

In some installations a heat shield may be advised. British Standard **BS 8303** should be followed if an Anevay heat shield is not fitted, with a minimum distance to the heat shield from the rear of the Traveller stove of 95mm and 90mm from the side of the stove to the heat shield.

A heat shield must include an air gap between the shield and the wall so the heat is not transferred. This gap needs to be ventilated by allowing air under the shield and out via the top.

When a single Anevay heat shield is fitted, this must be done to the centre of the stove. The shortest distance measured from the side of the main body of the stove past the edge of the heat shield to the combustible surface, must not be less than 450mm. This will be a diagonal line at roughly 45 degrees, if the wall is flat.

When a corner Anevay heat shield is fitted, the middle of the stove will line up with the corner joint. The distance between the rear of the stove and the corner joint should be 95mm. The corner angle should not be less than 90 degrees (if the corner is less than 90 degrees, alternative heat shielding will be required). Fitted in this way, the distance from the sides of the stove will not be less than 65mm and the distance shortest distance measured from the side of the stove past the edge of the heat shield to the combustible surface, will not be less than 450mm

Hearth

The Traveller Stove comes fitted with an integrated hearth to the width of 435mm and full length of 600mm. The D-section at the front should remain fitted during operation and slots in easily to the allotted recesses. A 12mm non-combustible hearth should be fitted beneath the base plate, extending to 150mm either side of the stove main body, and 225mm to the front of the stove door. The Traveller Stove has a cool hearth rating, with base temperatures not exceeding 100 degrees celsius.

Ventilation

In order for a stove to operate correctly there needs to be sufficient combustion air. For stoves of 5 kW and under, such as the Traveller Stove, a permanently open vent is sometimes required, usually in new build houses and extensions. This can depend on the air permeability (air leakage) of your property. Your HETAS installer should be able to guide you.

In addition, a stove **should not** be fitted in a room with an appliance such as an extractor fan, ceiling fan or tumble drier - it will affect the draw of the stove and could lead to fumes entering the room. All air vents should be positioned so that they are not liable to blockage.

In addition to the above considerations we recommend allowing for an air vent of 60mm diameter in any small sealed structure such as a van, Shepherds Hut, garden shed/office, ideally placed at low level. This is a provision for combustion air in small spaces and a carbon monoxide precaution.

Protecting Your Stove Surface

Your stove has been painted using a high temperature paint. This will give a long lasting and durable finish after the paint has cured. The process of curing occurs during the first few times you light the stove. Care must be taken when handling the stove prior to its first firings. It is at its most vulnerable at this stage. It is dry surface clean only - do not use damp cloths.

We recommend the use of organic rapeseed oil in order to create a protective barrier over the paint and steel of your stove. Spray on a light coating when the stove has just been lit, and the oil will plasticise as it heats and extend the lifespan of your stove.

Fumes

While the stove paint is curing, it will give off fumes. Please ensure you ventilate the room, opening doors and windows as necessary.

Smoke Emissions

Properly installed and operated, the stove will not emit smoke into your home with the exception of the occasional smoke from de-ashing and re-fuelling. Occasionally adverse weather conditions can cause a down-draught, this should be very occasional. Persistent smoke emission is dangerous and most not be tolerated. If smoke emission does persist:

- Open all doors and windows
- Let the fire go out
- Check flue or chimney for blockage
- Do not re-light the fire until cause of problem has been rectified. Seek professional help.

Hot Surfaces

The surfaces of the appliance and its flue are designed to get hot during operation. It is recommended to use a fireguard in the presence of children or vulnerable adults.

Safety Alarms

It is a legal requirement to install a Carbon Monoxide and smoke alarm when you install a solid fuel appliance such as a stove. Please see latest guidance for correct positioning.

Pre-lighting Checks

Before lighting the stove, it is important to check the system so as to ensure it is ready to be used:

- The loading door closes correctly and the rope seals and glass are intact.
- All labels and packaging have been removed (including from the flue system)
- Any access points in the flue are closed off.

Stove Maintenance

The chimney should be swept at least once per year, depending on use.

If the stove is left for long periods without use, ie over the summer, it is advisable to clean the stove thoroughly and leave all the vents open. This will help prevent any build-up of condensation and allow the stove to keep dry and limit internal corrosion.

The whole system should be checked after any prolonged period without use to ensure that it is free from blockage.

Glass Replacement

In the case that the glass on your stove door needs replacing, simply slide the glass piece upwards and out carefully, and slide a replacement piece back in to the slot. Replacement glass panes can be purchased at Anevay Stoves. Please contact info@anevay.co.uk and we will help you with this.

Warning

The Anevay Traveller Stove has been tested to BS EN 13240:2001 + A2:2004 safety standards. No unauthorised modification of the appliance should be carried out, as this will compromise the stove's compliance to safety standards.

Lighting Your First Fire

When your stove has been properly installed and you are ready to light your fire, locate the three packages from inside the stove body, marked "1", "2" and "3". These contain natural flammers which will burn low and create sufficient fire to cure the paint.

Removing the packaging, place the flammers from package 1 inside the stove body, keeping them in the centre of the stove for an even curing process. Ensure the stove lid is closed and the vent/slider is set to "open". Before closing the stove door onto the **first notch**, light the flammers in the stove body. Allow to burn for 15 minutes. Once the stove has cooled, repeat the process with packages "2" and "3". We still recommend that your first couple of fires are kept quite small to avoid any blistering of the paint.

Don't touch the surface with anything during the curing process. There is likely to be strong smell when the paint is curing, ventilate the room well, open windows/doors as necessary. Take extra care if anyone else in the household has breathing difficulties.

Your Traveller Stove is designed to be used intermittently - refuelling every 45 minutes to maintain operation at the nominal heat output.

The Traveller stove is very easy to use, however don't be disappointed if your first burn doesn't go exactly to plan. It can take practice to be able to cook efficiently and get a good burn going on your woodburning stove.

Practice makes perfect and the key is to enjoy your stove!



Appendix A: Traveller Stove Flue Kit



KIT COMPONENTS:

- Adaptor piece which connects single skin flue section to insulated flue section
- 500mm insulated flue section
- 1000mm insulated flue section
- Flashing kit with silicone sealant and screws
- Storm collar
- Insulated anti-downdraft cowl

CHIMNEY DESIGNATION:

EN1856-1 T600 N1 D V2 L50040 G60

INSTALLATION INSTRUCTIONS:

- Anevay Stoves are designed to support and carry their flue systems. In addition, our stoves have been tested to function with our proprietary flue systems that allow for shorter setups than the 4.5m height required by Document J and smaller diameter of 100mm (4").

The following strict requirements must be adhered to.

- The first section of flue exiting the stove **must** be an Anevay 4" single skin flue section, with a minimum length of 500mm.
- The flue must not contain any bends and should extend straight upwards from the stove.
- Additional sections can be added to the kit to increase the height but extending beyond 3.5m may require support brackets. Please consult with your HETAS installer / us as manufacturer in this regard .
- The distance from combustibles for the twin walled sections mainly affects the exit point and are as follows: 50mm from the flue surface to combustible materials; a minimum distance of 425mm from the top of the single skin flue to the ceiling; 300mm between the single skin flue and combustible surfaces (can be reduced with the use of a heat shield)
- Flashing kit instructions should be followed
- The termination should be at least 600mm from the weather surface in accordance with BS 6762-2. This can be reduced to 200mm on van installations where the weather surface is non-combustible metal.
- The anti-downdraft cowl allows for location in more turbulent air whilst maintaining draught and reducing stray embers.

ANEVAY



www.anevaystoves.com

Anevay takes no responsibility for the use or misuse of this product, or for any damage caused by using it and products are bought and used at owner's risk. We only recommend the use of dry seasoned timber as a solid fuel for the Traveller Stove. We recommend using a multitool or glove to operate the door and to open and close the stove lid as these get very hot during use. The Traveller Stove chimney flue should be cleaned regularly and well-maintained. The stove is a sealed unit, so with common sense you can protect yourselves. We recommend that you always put a mat or piece of fireproof / retardant material under your stove to protect against sparks.