



LE GOUVERNEMENT
DU GRAND-DUCHÉ DE LUXEMBOURG
Ministère de la Mobilité
et des Travaux publics

Département de la mobilité
et des transports

SOCIÉTÉ NATIONALE DE
CERTIFICATION ET D'HOMOLOGATION
S.A.

Registre de Commerce: B 27180

L-8070 Bertrange



Référence: E13*43R01/09*0640*02

Annexes: - Rapport technique
- Fiche de renseignements du constructeur

Bertrange, le 12 mai 2022

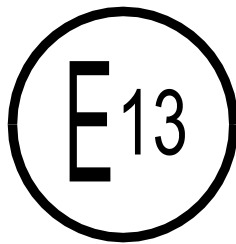

Communication concernant ⁽¹⁾ / Communication concerning ⁽¹⁾:

- **Délivrance d'une homologation** / approval granted
- **Extension d'homologation** / approval extended
- **Refus d'homologation** / approval refused
- **Retrait d'homologation** / approval withdrawn
- **Arrêt définitif de la production** / production definitely discontinued

d'un type de vitrage de sécurité conformément au Règlement N° 43
of a type of safety glazing material pursuant to Regulation N° 43

Numéro d'homologation:
Approval number:

E13*43R01/09*0640*02

Marque d'homologation:
Approval mark:

V-X/C

 43R-010640

- 1. Classe attribuée au vitrage de sécurité:**
Class of safety glazing material: Rigid plastic double-glazed units V-X/C
- 2. Description du type de vitrage:**
Description of the type of glazing: Please refer to Appendix 1, 2, 3, 4, 5, 6, 7, 8, 9, 10, 11 and 12 ⁽¹⁾ and in the case of windcreens, the list conforming to Appendix 13
- 3. Marques de fabrique ou de commerce:**
Trade names or marks: DOMETIC
Type:
Type: Dachluke "Mini – Heki"
- 4. Nom et adresse du fabricant:**
Manufacturer's name and address: Dometic Germany Krautheim GmbH
In der Steinwiese 16
57074, Siegen
Germany
- 5. Nom et adresse du représentant du fabricant (le cas échéant):**
If applicable, name and address of the manufacturer's representative: Not applicable

6. **Présenté à l'homologation le:**
Submitted for approval on: 24.03.2022
7. **Service technique chargé des essais d'homologation:** ATEEL S.à r.l.
Technical Service responsible for conducting approval tests: 14, op Huefdreisch
L-6871 Wecker
8. **Date du procès-verbal d'essai:**
Date of report issued by that Service: 20.04.2022
9. **Numéro du procès-verbal d'essai:**
Number of report issued by that Service: DEDOS1-AL-00002-02C00
10. **Homologation ⁽¹⁾:**
Approval is ⁽¹⁾: ~~Granted~~ / extended / ~~refused~~ / ~~withdrawn~~
11. **Motif(s) de l'extension d'homologation:**
Reason(s) for extension of approval: See Annex II of technical report
N° DEDOS1-AL-00002-02C00
12. **Remarques:**
Remarks: See Annex GI1 of technical report
N° DEDOS1-AL-00002-02C00
13. **Lieu:**
Place: Bertrange
14. **Date:**
Date: 12 mai 2022
15. **Signature:**
Signature:

Pour le Ministre de la Mobilité
et des Travaux publics



Alain DISIVISCOUR
Conseiller

Pour la SNCH

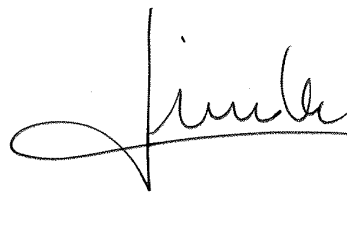

Laurent LINDEN
Directeur opérationnel



16. **La liste des documents déposés auprès de l'autorité d'homologation de type qui a délivré l'homologation, qui est annexée à la présente communication, peut être obtenue sur demande.**

The list of documents filed with the Type Approval Authority which has granted approval and available on request is annexed to this communication.

See INDEX to TYPE-APPROVAL REPORT

⁽¹⁾ **Biffer les mentions inutiles.**
Strike out what does not apply.



Référence: E13*43R01/09*0640*02

Annexes: - Rapport technique
- Fiche de renseignements du constructeur

Bertrange, le 12 mai 2022

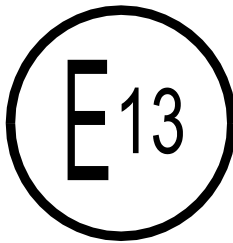

Annexe 1 - Appendice 7
Annex 1 - Appendix 7

Vitrages multiples
Multiple glazed units

**(Caractéristiques principales et secondaires suivant
l'annexe 12 ou l'annexe 16 du Règlement N° 43)**

(Principal and secondary characteristics as defined in
Annex 12 or Annex 16 to Regulation N° 43)

N° d'homologation:
Approval N°:

E13*43R01/09*0640*02

Caractéristiques principales:
Principal characteristics:

- Nature des vitrages multiples:
Composition of multiple glazed units:

~~Symmetrical~~ / asymmetrical

- Epaisseur nominale de l'espace:
Nominal thickness of the gap:

14 mm

- Méthode de montage:
Method of assembly:

Ultrasonic welding

**- Type de chaque vitre constitutive suivant les
annexes 5, 7, 9, 11 ou 14:**
Type of each glazing component as defined in Annexes 5, 7, 9, 11
or 14:

Outside: Cast acryl plastic (PMMA),
tinted (bright grey) or colourless,
nominal thickness 2 - 2,6 mm

Inside: Cast acryl plastic (PMMA),
transparent, colourless;
nominal thickness 2,0 mm

Pièces jointes:

Documents attached:

Une fiche pour tous les vitrages constitutifs d'un vitrage multiple symétrique conformément à l'annexe suivant laquelle ces vitrages ont été éprouvés ou homologués.

One form for all panes of a symmetrical multiple glazed unit in accordance with the annex under which the panes have been tested or approved.

Une fiche pour chaque vitrage différent constitutif d'un vitrage multiple asymétrique conformément aux annexes suivant lesquelles ces vitrages ont été éprouvés ou homologués.

One form for each different pane of an asymmetrical multiple glazed unit in accordance with the annexes under which these panes have been tested or approved.

Remarques:

Remarks:

All units produced according to this homologation are suitable for being mounted on the roof.
Light transmittance is less than 70 %.



Référence: E13*43R01/09*0640*02

Annexes: - Rapport technique
- Fiche de renseignements du constructeur

Bertrange, le 12 mai 2022

INDEX DU DOSSIER D'HOMOLOGATION INDEX TO TYPE-APPROVAL REPORT

	Numéro d'homologation: Approval number:	E13*43R01/09*0640*02
	Révision: Revision:	00
	Marque de fabrique: Trade name or mark:	DOMETIC
	Type: Type:	Dachluke "Mini – Heki "
1.	Procès-verbal d'essai: Test report:	N° DEDOS1-AL-00002-02C00
	- Technical report:	Page(s) 1 & 2;
	- Index:	Annex I1 - Page(s) 1 & 2;
	- General information:	Annex GI1 - Page(s) 1 & 2;
	- General test report:	Annex T - Page(s) 1 & 2.
2.	Dossier du constructeur: Report of the manufacturer:	N° ---
	- Manufacturer's information folder:	Annex MID - Page(s) <u>1 to 4</u> .
3.	Autres documents annexés: Other documents annexed:	Not applicable
4.	Date de délivrance de l'homologation initiale: Date of issue of initial type approval:	28.07.2005
5.	Date de la dernière délivrance de pages révisées: Date of last issue of revised pages:	Not applicable
6.	Date de la dernière délivrance d'une homologation révisée: Date of last extension:	12.05.2022

Tests and inspection concerning

SAFETY GLAZING MATERIALS

according to the ECE Regulation No. 43 including all amendments up to Supplement 9 to the 01 series of amendments - Date of entry into force: 29.05.2020

Manufacturer: Dometic Germany Krautheim GmbH
In der Steinwiese 16
57074, Siegen
Germany

Type: Dachluke " Mini - Heki "	Type Approval No.: E13*43R01/09*0640*02	Manufacturer: Dometic Germany Krautheim GmbH
------------------------------------------	---------------------------------------------------	-----------------------------------------------------------

Conclusion: The tests and checks carried out have shown the compliance of the type described in this report and the attached annexes with the Regulation mentioned above.

Wecker, 20.04.2022



Sven Regneri
Ingénieur Inspecteur

Index: see Annex I1
A reproduction of this document, except in full, is prohibited.

1 Tests and inspection results

Refer to Annex T

2 Type and variants

The tests and inspections carried out and described in this technical report have been selected in order to include the following variants and versions of the type and its equipments, as far as these are relevant for the topic of this report, into the judgement:

As stated in Annex MID (Manufacturer's Information Document):	Item
- thickness of the component sheets	1.1.4
- width of air gap between the component plastic sheets	1.1.6
- colouring of the plastic sheets	1.1.7

3 Remark

3.1 General:

The described glazing are plastic rooflight with a light transmittance which is less than 70 %. They are mounted in a position not requisite for driver visibility and where no head contact is possible.

- two alternative manufacturers of the basic material: Barlo , Degussa

3.2 Remark to extension 01:

A new manufacturer of the basic material (LG MMA) has been added. New tests have been performed.

3.3 Remark to extension 02:

New tests have been performed according to constructive changes of the outer pane and the new manufacturers of the basic material (Röhm GmbH, Polycasa GmbH and LX MMA).

The tests have been subcontracted to DEKRA.

DEKRA Automobil Test Center is notified by the KBA and the RDW as a technical service for the regulation. In addition, DEKRA Automobil Test Center is accredited by the DAkkS for the regulation according to ISO 17025.

More details on Annex I1.

Compilation of Dossier No.: DEDOS1-AL-00002 - Dometic Germany Krautheim GmbH

Technical Report no.: DSA0002A remains unused

Extension 01

Technical Report no.: DSA0002B

page 1 and 2

Composition of Annex:

I1:	Index	page 1
GI1:	General Information	page 1
T:	General Test Report	page 1 to 2
MID:	Manufacturer's Information Document	page 1 to 4

Index of the appendices to the Manufacturer's Information Document: see Annex MID, item 3

Content of Report:

to be changed:

- technical service
- the editorial arrangement
- Manufacturer name and address
- Trade mark

to be added:

- new manufacturer of the basic material

to be updated:

- the Regulation up to Supplement 7 of Series 01
 - the approval number to the new format
 - approval mark
 - class of safety glazing material
-

Compilation of Dossier No.: DEDOS1-AL-00002 - Dometic Germany Krautheim GmbH

Extension 02

Technical Report no.: DEDOS1-AL-00002-02C00

page 1 and 2

Composition of Annex:

I1:	Index	page 1 and 2
GI1:	General Information	page 1 and 2
T:	General Test Report	page 1 and 2
MID:	Manufacturer's Information Document	page 1 to 4

Index of the appendices to the Manufacturer's Information Document: see Annex MID, item 3

Reasons for extension:

to be changed:

- Editorial changes and corrections
- the classification of the safety glazing material to V-X/C
- Constructive change of the outer pane
- New method of assembly of the single panes, ultrasonic welding

to be added:

- New manufacturer of the basic material (Röhme GmbH, Polycasa GmbH and LX MMA)
- Producer (Assembly plant)

to be deleted:

- Manufacturer of the basic material (Barlo , Degussa , LG MMA)

to be updated:

- the Regulation to Supplement 9 of Series 01
 - Manufacturer name and address
 - Annex MID, Description document
 - Appendix 3.1, Approval mark example
 - Appendix 3.2, Drawing of the assembly
 - Appendix 3.3, Photos of the assembly
-

General Information <Dometic Germany Krautheim GmbH>

Numbering according to annex 1 of the ECE Regulation No. 43

1.	Class of safety glazing material:	rigid plastic double-glazed units V-X/C
2.	Description of the type of glazing:	please refer to appendix 7
3.	Trade names or marks:	DOMETIC
4.	Manufacturer's name and address:	Dometic Germany Krautheim GmbH In der Steinwiese 16 57074, Siegen Germany
5.	If applicable, Name and address of manufacturer' s representative:	not applicable
6.	Submitted for approval on:	24.03.2022
7.	Technical service responsible for conducting approval tests:	ATEEL S.à r.l. 14, op Huefdreisch L-6871 Wecker
8.	Date of report issued by that service:	20.04.2022
9.	Number of report issued by that service:	DEDOS1-AL-00002-02C00
12.	Remarks Assembly plant:	TOMPLAST d.o.o. PE Semic Obrtna cona 16 8333 Semic Slovenia

General Information <Dometic Germany Krautheim GmbH>

Appendix 7 of Annex 1 of the Regulation No. 43

Principal characteristics:

Composition of double-glazed units (symmetrical/asymmetrical):		asymmetrical
Nominal thickness of the gap:		14 mm
Method of assembly:		ultrasonic welding
Type of each glazing component:	Outside:	cast acryl plastic (PMMA) tinted (bright grey) or colourless nominal thickness 2 - 2,6 mm
	Inside:	cast acryl plastic (PMMA) transparent, colourless nominal thickness 2 mm
Documents attached:		refer to Annex I1 of the technical Report
Remarks:		light transmittance is less than 70%.

General Test Report

The data in this section refer only to the items submitted to testing or inspection.

0 Abstract

0.1 Type Dachluke " Mini - Heki "

1 Dates and resources

1.1 Date of receipt of test item 24.03.2022

1.2 Date of Inspection 24.03.2022

1.3 Place of Inspection DEKRA Automobil GmbH
Automobil Test Center
Senftenberger Straße 30
D-01998 Klettwitz

1.4 Testing site and testing equipment:

All measuring and test equipment used to carry out the inspections are in accordance with ISO 17025 and the regulatory act(s) applied.

2 Test object

The tests were conducted with a double glazing unit which is representative of the type to be approved.

2.1 Description

Type: Dachluke " Mini - Heki "

Design: Outside: cast acryl plastic (PMMA)
tinted (bright grey) or colourless
nominal thickness 2 - 2,6 mm
Inside: cast acryl plastic (PMMA)
transparent, colourless
nominal thickness 2 mm

General Test Report

3 Tests and inspections

3.1 General

The requirements of item 6 of the Regulation are fulfilled.

3.2 Particular requirements

3.2.1 Flexibility test

The requirements according to Annex 16, paragraph 3 of the Regulation are fulfilled.

3.2.2 Headform test

Test not applicable according to item 4.3.4 of paragraph 4 of Annex 16 of the Regulation.

3.2.3 Mechanical strength test 227g ball test

The requirements according to Annex 16, paragraph 5 of the Regulation are fulfilled.

3.2.4 Test resistance to the environment

3.2.4.1 Test of resistance to abrasion

Test not applicable according to item 6.1.3.3 of paragraph 6.1 of Annex 16 of the Regulation.

3.2.4.2 Test of resistance to simulated weathering

The requirements according to Annex 16, paragraph 6.2 of the Regulation are fulfilled.

3.2.4.3 Cross-cut test

Test not applicable according to item 6.3.1 of paragraph 6.3 of Annex 16 of the Regulation. Only coated products are subject to cross-cut testing.

3.2.4.4 Resistance-to-humidity test

The requirements according to Annex 16, paragraph 6.4 of the Regulation are fulfilled.

3.2.5 Optical Qualities

Test not applicable. The requirements according to Annex 16, paragraph 7 of the Regulation do not apply to products which are not requisite for driver visibility.

3.2.6 Fire resistance test

The requirements according to Annex 16, paragraph 8 of the Regulation are fulfilled.

3.2.7 Resistance to chemicals

The requirements according to Annex 16, paragraph 9 of the Regulation are fulfilled.

The safety glazing for the opening roof has a light transmittance below 70%. The glazing bears the additional symbol V specified in item 5.5.2 of the regulation.

The requirements of item 4.2.3.1 of annex 24 of the Regulation are fulfilled.

Description Document

0. General Information

- 0.1 Name and address of manufacturer: Dometic Germany Krautheim GmbH
In der Steinwiese 16
57074, Siegen
Germany
- 0.2 Type: Dachluke " Mini - Heki "
- 0.3 Manufacturer's of the basic material: Röhm GmbH, Polycasa GmbH , LX MMA

1. Technical Description

- 1.1 Principal characteristics:
- 1.1.1 Trade names or marks: DOMETIC
- 1.1.2 Classification of the material by the manufacturer: a) Outside pane
b) Inside pane
- 1.1.3 Chemical designation of the component sheets: a) and b) rigid plastic double-glazed units
made of cast acryl plastic (PMMA)
- 1.1.4 Thickness of the component sheets: a) Outside pane 2 - 2,6 mm
b) Inside pane 2,0 mm
- 1.1.5 Process of window manufacture: the outside and inside panes are ultrasonic
welded together
- 1.1.6 Width of air gap between the component plastic sheets: 14 mm (nominal gap)
- 1.1.7 Colouring of the plastic sheets: a) Outside pane tinted (bright grey) or
colourless
b) Inside pane transparent, colourless
- 1.1.8 Nature and type of coating: no coating on either pane
- 1.2 Secondary characteristics: not applicable
2. Remarks (assembly plant) TOMPLAST d.o.o.
PE Semic
Obrtna cona 16
8333 Semic, Slovenia

3. Appendices

- Approval mark example
 - Drawing of the assembly
 - Photos of the assembly
- 3.1 Approval mark example

V-X/C



43 R - 01XXXX

3.2 Drawing of the assembly

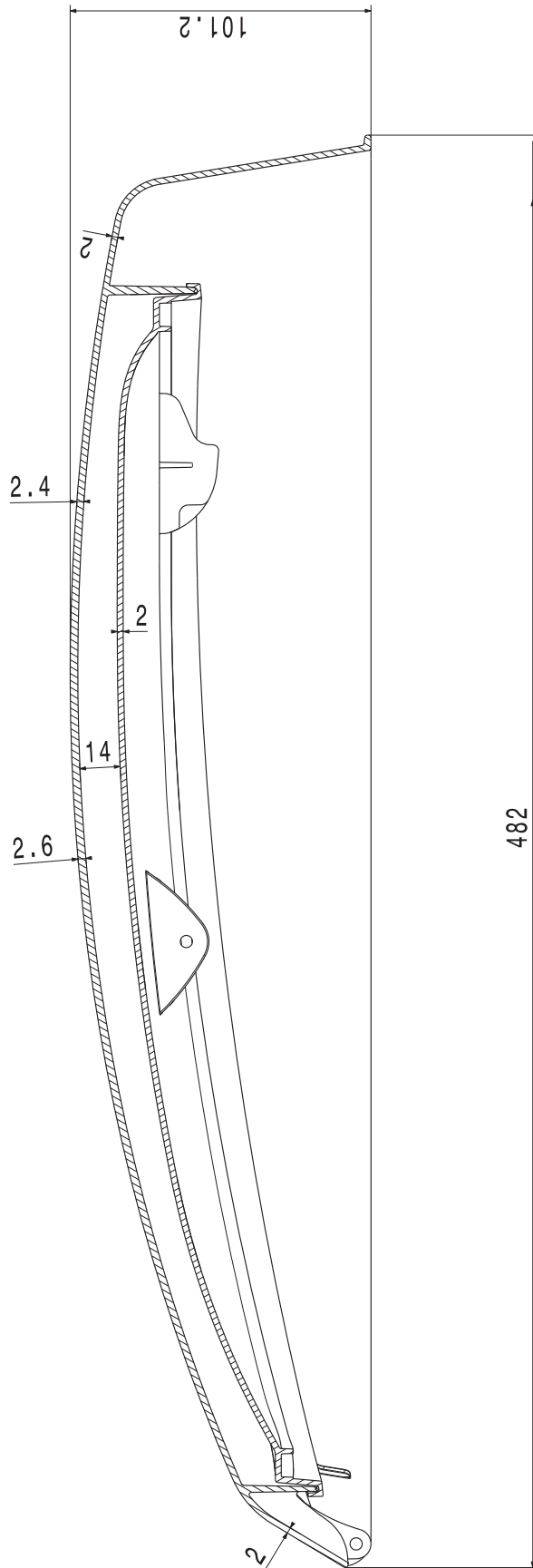

Pos:	Teile-Nr:	Bezeichnung:	Menge:
1	SP 3192	Innenglas	1
2	SP 3193	Aussenglas	1
3	D 1047	Dichtung	1
4	SP 8024	Zwischenschaltstopfen	1

MISSING DIMENSIONS ARE TAKEN BY THE 3D CAD DATA
Fehlende Masse und Angaben sind dem 3D-DATENSATZ
ZU ENTNEHMEN

APPROVED RAW MATERIAL / FREIGELEGTE WERKSTOFFE
EVONIK PLEXIGLAS RESIST AKSBR
POLYCARA CRYLON KR 2010/1
LG HES33

DOMETIC Mobile living machinery		Werkstoff / Free von Pw, Cr-VI, Co, Ni und Pb, PBE gemäss Richtlinien des BfG (BfG 1997/7096) Material / Free of Pw, Cr-VI, Co, Ni and Pb, PBE according to Directives ELV 2002/95/EC and REACH 1907/2006	Masstab/Scale: 1:2	Gew./Weight: -g
		Werkstoff/Material: PMMA		
		Freimasstoleranz/Tolerance: DIN 16742 T04		
		Benennung/Name: ZB Glas		
		--- --		
		Zeichnungsnummer/Drawing No.: BG 5011		
		Blattnummer		
		1 Bl.		
		1 Bl.		
		Mit CATIA V5 erstellt		
		A 0		

Index	Änd./Modification	Dat.	Name
e	Aussenglas geän.	21.01.22	RT Thumann
d	Innenglas geän.	17.12.21	RT
c	Aussenglas geän.	26.05.21	RT
b	Schweissbereich		
a	Freigabe	06.04.21	RT
		03.03.21	RT

© Für diese Zeichnung behalten
wir alle Rechte vorbehalten.
The author reserves all rights.

© DIN ISO 128-30

3.3 Photos of the Panes

